

⚠ WARNINGS From '14POINT7' Spartan 3Dv2 Manufacturer ⚠



Warranty page 3

- Do not connect or disconnect the Wideband Sensor while Spartan 3Dv2 is powered.
- The Sensor will get very hot during normal operation, please be careful when handling it.
- The Sensor must be controlled by Spartan 3Dv2 While in an active exhaust stream. Carbon soot from an active exhaust can easily build up on an unpowered sensor and foul it.
- Spartan 3Dv2 should not be used on public roads.
- Sensor powered before your engine is running will damage the sensor. Starting the engine can move condensation in your exhaust system to the sensor. If the sensor is already heated this can cause thermal shock and the ceramic internals inside can shatter with rapid temperature changes.
- Leaded fuels expect short Sensor life: 100-500 hrs.
- Spartan 3Dv2 is water resistant to splashes: Can be installed in engine bay.



📦 What's Included In Your Kit?

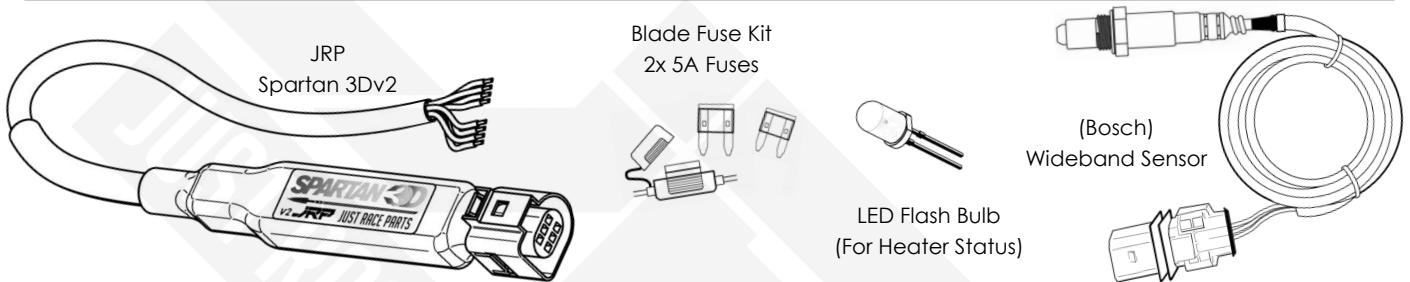

⚡ Connect Spartan To Multigauge, ECU or Other Display

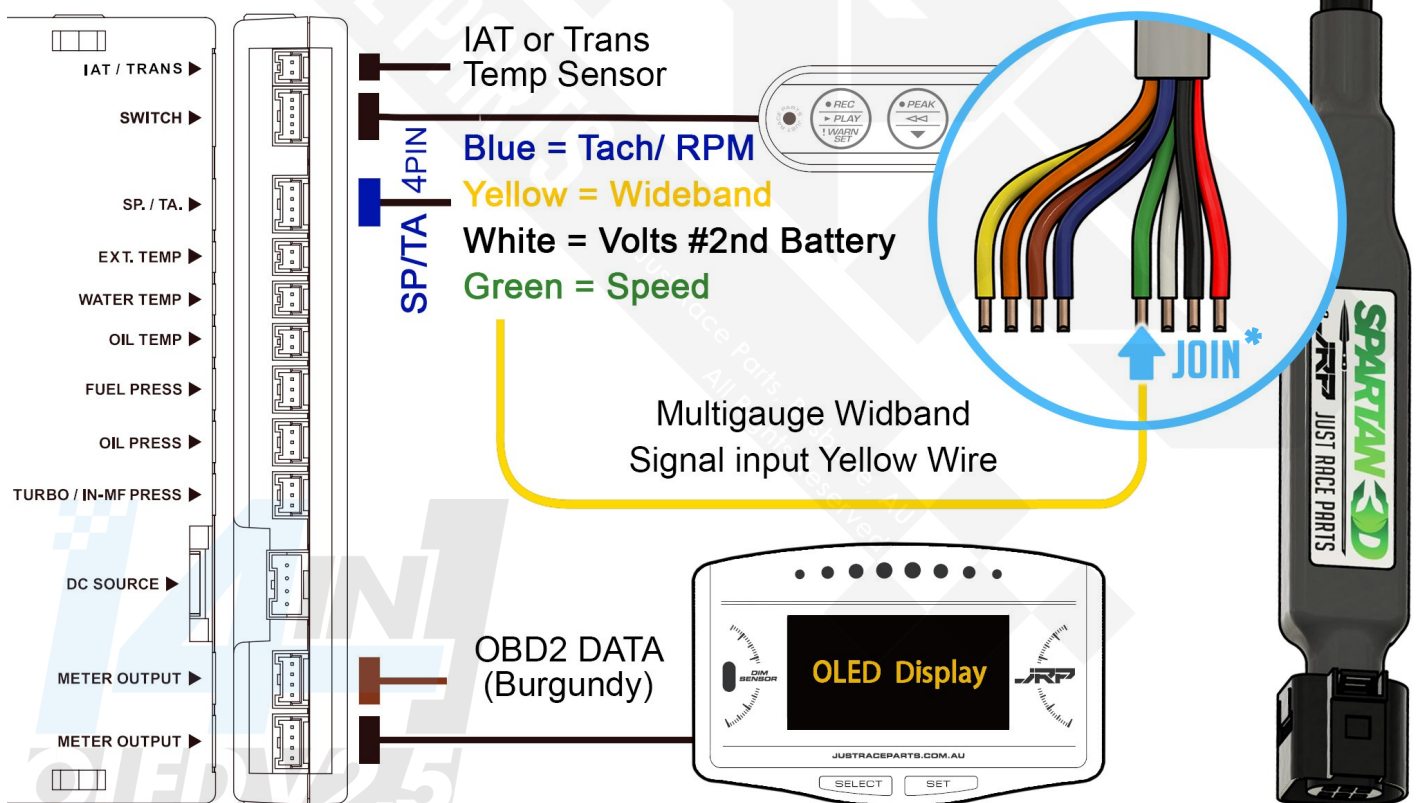

Spartan 3D v2 Power wiring detailed on Page 2. Connect **Spartan Green signal wire** to AFR input/ display device, Where "0v to 5v analogue input signal is required. On the JRP Multigauge this is the **Yellow wire** from the 4 pin SP/ TA Wire

Spartan 3Dv2 Signal Output Information: Green Wire (Wideband signal) The Spartan 3Dv2 from JRP has a "0v to 5v" analog output signal, 0[v] @ 0.69 [Lambda] Linear to 5[v] @ 2.76 [Lambda], which equates to 10 to 40 AFR. Output is a 12 Bit DAC with a 0.1% voltage reference. If this wire is to be shared between a gauge and ECU/ datalogger ensure same "gauged" wire is used, and wire length as short as possible to avoid signal degradation.

Negative terminal on the vehicles battery must be removed before crimping/ joining wires

⚡ How To Connect Spartan Wiring - Follow All Warning information!

***WARNING! READ THIS PAGE CAREFULLY before powering unit. Incorrect power sequence can damage sensor & void Factory warranty.**

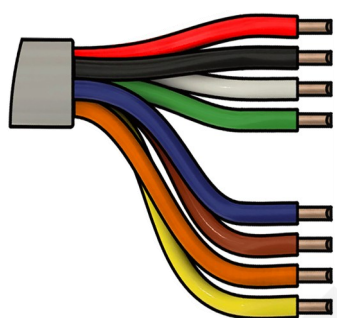

RD Spartan Power	Engine running 12v (+)
BK Spartan GND	Ground at ECU/ cabin
WH O2 Heater GND	Ground engine block
GR - Wideband Out	Gauge yellow signal
BL - Temp Indicator	LED long leg
BR - Narrowband	(N/A for diesel fuel)
OR - UART TX	(Programming)
YL - UART RX	(Diagnostics)

- **Red** Fused with "Caramel 5A" blade fuse (included).
 - **Black/White** "Ground Wires" Must be connected to 2x different locations! Heater ground on the engine block. Spartan to share "ground" with ECU, gauge or inside cabin. **DO NOT JOIN BLACK & WHITE GROUND WIRES!**
 - **Green** Wideband 0v to 5v analog signal output, used to transmit wideband signal to JRP Gauge Products, ECU's & Dataloggers. Connect this to yellow wire on JRP Gauges.
 - **Blue** Connect to Long Leg/ Positive Side of an LED Light. A light connected here will illuminate/ flash to indicate the temperature of the internal heater element inside the sensor
- *Signal specifications + LED Behaviour on page 4 above notes.**

✓ **IMPORTANT:** "Spartan 3Dv2, sensor and heater" must be powered only after engine has started. (The same 12v (+) should be used). A good place to access this 12v is from the fuel pump circuit after the relay on EFI cars.

💡 LED Flasher: For Wideband Heater Status



LED Blink Speed Spartan 3D : Red solid light, Ok. Very Slow (1 blink 8 Every Seconds) Sensor too cold, waiting for Wideband to heat sensor to 350c. Fast (2 blinks every sec) Sensor too hot. Handy Tip: You can Install a surface mount 12v led for custom installations.
Boot loading: LED Flash 6 times - then off for 5 sec: Device is attempting the boot loader sequence, you must check your wiring. This is only possible when Spartan 3Dv2 is wired incorrectly. Other flash combinations are also possible when wrong. [Help from JRP?](#)

🔍 How Does An Oxygen Sensor Work?

If given some thought, it's actually pretty crazy the harsh environment oxygen sensors are required to operate in. Put simply: Oxygen sensors read oxygen levels in hot gasses traveling through the exhaust system. The sensor will produce an accurate voltage signal within 'milliseconds' then send that information through specialised cables to be interpreted by a "Wide band controller" or "Electronic control unit (ECU)."

🎓 Important - How Does An Oxygen Sensor Work? (In Detail)

The sensor element tip is made from a special material called Zirconium-Dioxide. When the sensor element reaches a temperature of 400c or more, Oxygen ions (Electrically charged gas particles) are able to dissolve through this Zirconium-Dioxide material. This unique material reaction also produces a reliable electronic signal which makes it possible to measure if there is a difference in oxygen concentrations on either side of the element.

To ensure that the sensor reaches this required temperature quickly. A separate ceramic heater is positioned inside the element. Within 15 seconds the heater can reach temperatures over 600c degrees to ensure that this unique reaction can take place and produce a reliable signal for the Wide-band or ECU to interpret. (internal temperatures, caution while handling - external temperatures can still burn cause burns or injury)

WARNING! Oxygen sensors used incorrectly are vulnerable to thermal shock! Thermal shock is highly likely if "liquid" water hits the sensor while it's at operational temperature.

"But why would I have water in my exhaust?" Great question! Well that's actually pretty normal. You see, if a vehicle is used for more then a few minutes it will come up to normal operating temperature. When it is turned off, fresh air from the environment will enter the exhaust system. When this "air" is allowed to cool slowly, it will build up water condensation on all surfaces inside the exhaust system. So the next time you start the vehicle from cold, exhaust gasses will push most of the condensed water droplets out of the way. Maybe a teaspoon of actual liquid will come out the tail pipe, but most water will burn off as steam in the first 2 minutes.

"So why is all this important to know?" To protect the sensor element tip and reduce the likelihood of thermal shock from water, We need to ensure that the sensor only activates the internal heating element **AFTER THE ENGINE HAS STARTED**. So, that means it is essential to wire your Spartan 3Dv2 wideband controller so that it only provides direct power to the oxygen sensor heater: after the engine has started running.

P.S This water vapor that normally accumulates inside all exhaust systems helps explain why old exhausts rust from the inside out... Hmm, the more you know! 🤔

Following information is directly credited from "Bosch" (Oxygen Sensor Manufacturer):

"In the warm-up phase at engine start, the sensor is operated with reduced heater power... The heater power must only be increased when the presence of condensed water in the exhaust gas system can be ruled out. The sensor's ceramic element is heated up quickly after heater start-up. Prior to heating the ceramic element, it must be guaranteed that there is no condensed water present. This could damage the hot ceramic element. Never switch on sensor heating or the control unit before engine start. The sensor installation location design must be selected in a way to minimize, or eliminate, condensed water on the exhaust gas side from contacting the sensor. If this is not possible by design measures, the start of the sensor heater must be delayed until demonstrably no more condensation water appears."

Oxygen Sensor Exhaust Location Requirements...

The Wideband Oxygen Sensor should be installed between the 10 o'clock and the 2 o'clock position, less than 60 degrees from vertical, this will allow gravity to remove water condensation from the sensor. The Oxygen Sensor must be installed before catalytic converters. The sensor should be installed about 600mm (2ft) away from the engine exhaust port - in Naturally aspirated engines. For Turbocharged engines, the sensor can be installed immediately after the turbocharger (In the Dump Pipe).

Note: Diesel Engines tuned with excessive soot from extremely rich AFR's can shorten the life of oxygen sensors.

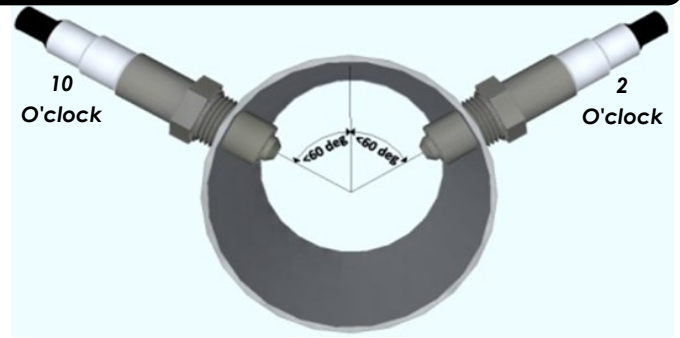

14point7 warrants Spartan 3Dv2 to be free from defects for 2 years, sensors are consumable, and may not be warranted after use. "14Point7 is liable for damages only up to the purchase price of its products."

Record the date of purchase here for warranty purposes _____.

Notes: _____

